

# Picosecond-pulse amplification with an external passive optical cavity

Eric O. Potma, Conor Evans, and X. Sunney Xie

*Department of Chemistry and Chemical Biology, Harvard University, 12 Oxford Street, Cambridge, Massachusetts 02138*

R. Jason Jones and Jun Ye

*JILA, National Institute of Standards and Technology and University of Colorado, Boulder, Colorado 80309-0440*

Received March 25, 2003

We experimentally demonstrate the amplification of picosecond pulses at high repetition rates through the coherent addition of successive pulses of a mode-locked pulse train in a high-finesse optical cavity equipped with cavity dumping. Amplification greater than 30 times is obtained at a repetition rate of 253 kHz, boosting the 5.3-nJ pulses from a commercial mode-locked picosecond Ti:sapphire laser to pulse energies of more than 150 nJ. © 2003 Optical Society of America

OCIS codes: 320.7080, 140.4480, 300.6220.

The nanojoule-scale pulse energies obtained directly from a mode-locked Ti:sapphire laser are often inadequate for many ultrafast spectroscopic experiments and frequency conversion schemes. Active pulse amplification of the oscillator's output has been widely used to boost pulse energies to the millijoule regime at repetition rates of 1 to 10 kHz. Such amplified ultrashort pulses have allowed, among other things, efficient frequency conversion schemes and the study of extremely nonlinear light-matter interactions.<sup>1</sup> However, many experiments do not require pulse energies as high as several millijoules and would benefit from higher repetition rates.

Ti:sapphire regenerative amplifiers are capable of generating high-repetition-rate pulse trains (250 kHz) with microjoule pulse energies.<sup>2</sup> Alternatively, pulses with moderate energies have been obtained directly from the oscillator with long-cavity designs<sup>3</sup> and cavity dumping.<sup>4-6</sup> Because the latter two approaches are not based on active amplification stages, they represent a much simpler and cost-effective means to enhancing pulse energies. Long-cavity lasers can provide pulse energies of 90 nJ at repetition rates as low as 4 MHz,<sup>4</sup> and cavity dumping allows flexible control of the pulse repetition rates as high as several megahertz.<sup>5</sup> However, in Ti:sapphire systems one can typically boost peak powers by only as much as ten times, limited by the maximum pulse energy adequate for stable Kerr lens mode locking, yielding pulse energies as high as ~100 nJ.<sup>4</sup>

Enhancement of laser light can also be realized through the coherent storage of radiation in a high-finesse cavity without a gain medium. Passive optical cavities have been used to increase the intracavity field from cw lasers to improve the efficiency for nonlinear optical interactions. Heupel *et al.*<sup>7</sup> have shown that portions of the stored energy can be switched out of the closed cavity through acoustic-optic dumping, resulting in a nanosecond-pulsed output with high peak powers. Similar intracavity experiments have been performed with mode-locked lasers for nonlinear

harmonic generation<sup>8,9</sup> and sensitive cavity ring-down spectroscopy,<sup>10</sup> to name a few.

It has been proposed, both in a recent patent<sup>11</sup> and in the scientific literature,<sup>12</sup> that this approach can be extended to amplify pulses from a mode-locked laser. The coherent superposition of mode-locked pulses stored in a passive optical cavity results in a single amplified pulse when switched out. The use of a passive cavity also offers the unique ability to effectively amplify pulses at frequencies for which no suitable gain medium exists, such as for the infrared pulses from different-frequency mixing or the ultraviolet light from harmonic generation. Unlike cavity-dumped laser systems, the pulse energy is not limited by the saturation of a gain medium or a saturable absorber needed for mode locking. Instead, the pulse energy can continue to build up inside the passive storage cavity until limited by cavity loss or dispersive pulse spreading. Efficiently building up pulse energy inside the passive optical cavity requires active stabilization of all cavity modes relative to the frequency comb of the incident pulse train. Intracavity dispersion can distort the stored pulse and limit efficient energy buildup. Jones and Ye<sup>12</sup> have performed calculations showing that intracavity dispersive effects are nearly negligible for picosecond pulses, while dispersion compensation can extend this amplification technique to sub-50-fs pulses.

In this Letter we experimentally demonstrate the use of a passive optical cavity as a pulse amplifier. We have chosen to focus on amplification of picosecond pulses, which avoids complications arising from intracavity dispersion. The layout of the amplifier is depicted in Fig. 1. The 835-nm output of a mode-locked 3.4-ps Ti:sapphire laser is fed into a folded six-mirror ring cavity. A mirror with 0.95% transmission is used as the coupling mirror. So that the cavity finesse is not compromised, all the other intracavity mirrors have ion-beam-sputtered coatings on superpolished substrates with a reflectivity greater than 99.997%. The cavity incorporates a 3-mm Bragg

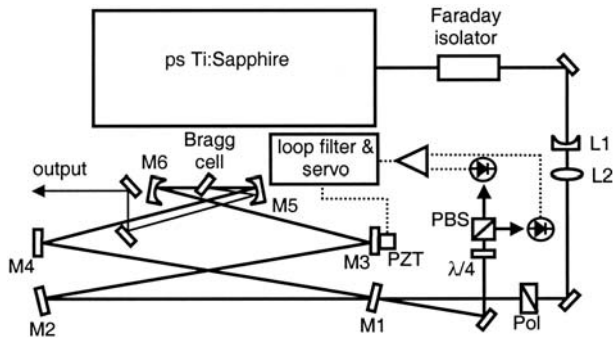

Fig. 1. Schematic of the passive optical amplifier. The Ti:sapphire laser (Coherent, MIRA 900) is pumped by a 5-W, 532-nm laser (Coherent, Verdi V5). L1, concave lens ( $r = -75$  mm); L2, convex lens ( $f = 125$  mm); Pol, polarizer; M1, output coupler (0.95% at 835 nm) (CVI); M2–M4, high reflectors ( $R > 99.997\%$ ) (Research Electro Optics); M5, M6, concave high reflectors ( $R > 99.997\%$ ,  $r = -100$  mm) (Research Electro Optics); Bragg cell, 3-mm fused silica cavity dumper (Harris) driven by a 16-W, 10-ns rf pulse cavity dumper driver (APE Berlin); PBS, polarizing beam splitter;  $\lambda/4$ , quarter-wave plate; PZT, piezoelectric transducer. Note: the mention of any specific company is for technical communication only and does not represent endorsement.

cell placed under Brewster's angle, which acts as an acoustic optic cavity dumper. The beam waist inside the crystal is calculated as  $\sim 20$   $\mu\text{m}$ . A fused silica cell was chosen because of the high laser damage threshold of this material. The free spectral range (FSR) of the cavity is set to the 76-MHz repetition rate of the pump laser, while the cavity resonances are actively locked to the average frequency of the laser. The error signal for the feedback loop is derived from the polarization-sensitive detection scheme of Hänsch and Couillaud<sup>13</sup> and is used to drive a piezoelectric transducer attached to one of the cavity mirrors.

The maximum energy that can be stored in the cavity depends on the total cavity losses ( $L$ ) and the transmission of the coupling mirror ( $T$ ). When the cavity modes are properly locked to the frequency comb of the incoming pulse train, the intracavity pulse amplification factor  $N$ , in the absence of dispersion effects, can be expressed as

$$N = \frac{4T}{L^2} = 4T \left( \frac{F}{2\pi} \right)^2, \quad (1)$$

where  $F$  is the cavity finesse. Efficient intracavity pulse amplification occurs when the transmission of the input-coupling mirror matches that of the remaining cavity losses (impedance matching). In this case the intracavity enhancement reduces to  $N = F/\pi$ , and the maximum amplification is in theory limited only by the attainable cavity finesse.

In our cavity, losses are primarily introduced by scattering or absorption in the coupling mirror and Bragg cell. We have found that losses inside our Bragg cell and at its faces are at least 0.2%, which could be suppressed by selecting a higher-quality cell with superpolished surfaces. With a 0.95% coupler the cavity is slightly undercoupled; i.e., the transmission of the coupling mirror is larger than the estimated remain-

ing losses of the cavity. A cavity finesse of 546 would be obtained if no further losses were present. However, based on measurements of the intracavity energy buildup, a finesse of 349 is estimated, indicating an additional 0.65% loss in the cavity, most likely due to loss in the input coupler. Under these conditions it is calculated that the intracavity power accumulates to 90% of its steady-state level within  $\sim 350$  round trips, corresponding to 4.5  $\mu\text{s}$ .

When the external cavity is locked to the mode-locked laser, an intracavity beam builds up displaying a clean  $\text{TEM}_{00}$  spatial pattern. We have observed that, although the incident beam exhibits a nonperfect  $\text{TEM}_{00}$  profile, the intracavity beam retains its clean spatial mode as determined by the eigenmodes of the amplifier cavity. In addition, the accumulation of several hundreds of pulses effectively averages out high-frequency amplitude fluctuations on the incoming pulse train and renders a stable circulating pulse.

Figure 2(a) shows the measured intracavity amplification factors of the passive amplifier as a function of input laser power. With 100 mW of incident beam power, amplifications as high as 130 times are achieved, reaching average powers of 13 W in the resonator. Lower amplifications are seen when the pump power is increased. At pumping powers of 500 mW the intracavity power increases to  $\sim 50$  W, an amplification of 100 times. The decreasing amplification with pump power could be caused by nonlinear optical processes in the fused silica cell. Stretching the input pulses or slightly reducing the spot size in the Bragg cell to lower the peak intensity of the

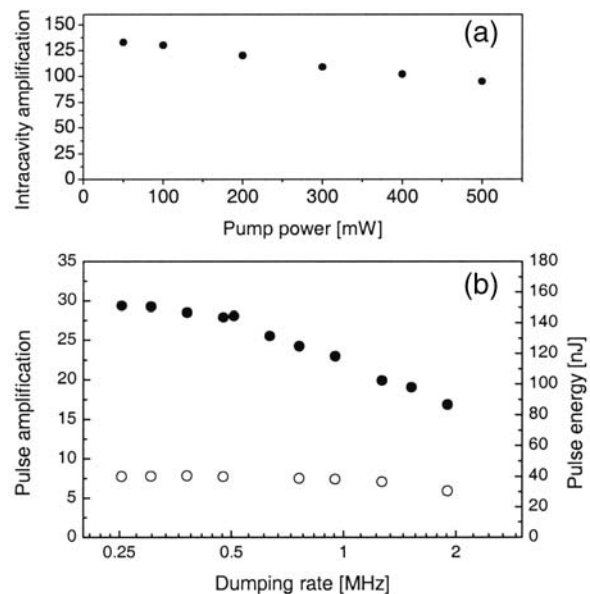

Fig. 2. Pulse amplification with the passive optical amplifier. (a) Intracavity enhancement for various average powers of the incoming pulse train. (b) Pulse amplification as a function of dumping frequency with single-pass dumping efficiencies of  $\sim 7.5\%$  (open circles) and  $\sim 30\%$  (solid circles). Pulse energies (right axis) are obtained when seeding the amplifier with 400 mW from the Ti:sapphire laser. Note that dumping at frequencies beyond 2 MHz is limited by dumper electronics rather than by optical constraints.

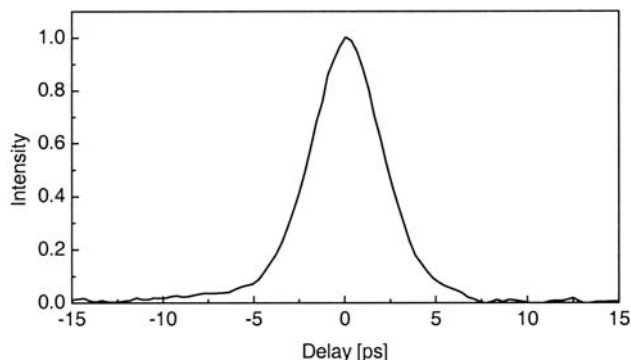

Fig. 3. Autocorrelation of 140-nJ amplified pulses at 475 kHz. Pulse width amounts to 3.4 ps, assuming a Gaussian envelope.

incident pulses can potentially reduce competing nonlinear mechanisms.

Amplified pulses can be extracted from the resonator when a fraction of the circulating pulse is switched out with the cavity dumper. Upon dumping, the locking point of the differential error signal remains unaltered, which ensures uninterrupted operation of the cavity. In Fig. 2(b) the amplification of the dumped pulse is shown as a function of the dumping frequency with 400 mW of laser beam power. For a dumping efficiency of  $\sim 7.5\%$  the output pulse is amplified eight times at a repetition rate of 475 kHz. This amplification factor is retained for dumping frequencies as high as 760 kHz. The pulse energy decreases at higher dumping rates because there is insufficient time to restore the steady-state cavity powers between the dumping events. When the dumping efficiency is increased to  $\sim 30\%$ , pulse enhancements of 30 times are obtained at 253 kHz, yielding pulse energies higher than 150 nJ (38 mW of total average power). Again, lower pulse powers are seen at higher dumping rates due to incomplete cavity buildup dynamics. Nevertheless, pulse energies of more than 80 nJ are attained at a dumping rate of 1.9 MHz. It is also worth noting that Fig. 2(b) shows a cavity field buildup time of  $\sim (0.7)^{-1} \mu\text{s}$ , leading to a cavity linewidth of  $\sim 0.7/\pi$  MHz. Hence the cavity finesse is  $(76 \text{ MHz}/0.7 \text{ MHz}) \times \pi \sim 341$ , which is close to the previously estimated value.

The autocorrelation of the dumped pulse is displayed in Fig. 3. A Gaussian fit reveals a FWHM pulse width of 3.4 ps, which is similar to the temporal width of the input pulses. This complies with previous calculations,<sup>12</sup> which indicated that cavity dispersion has a modest effect on the amplification of pulses with widths greater than 1 ps. For amplification of very short pulses (sub-50-fs) intracavity dispersion compensation is mandatory to ensure that the FSR remains constant over the full bandwidth of the stored pulse at each round trip. We also note an interesting pulse-shaping control capability via the cavity when the spectrum associated with the amplified pulse is narrowed. Specifically, by deliberately setting the cavity FSR to be slightly different from the

incoming pulse repetition rate, we can variably control the pulse width from 3.4 ps to more than 10 ps at the expense of pulse power.

In conclusion, we have demonstrated experimentally that amplification of the picosecond pulses of a mode-locked laser can be achieved through coherent addition of the pulses in a passive optical cavity. The present pulse amplification scheme provides three times higher pulse energies than what can be achieved by direct cavity dumping from a mode-locked laser while still maintaining relatively high repetition rates (hundreds of kilohertz). The passive amplifier delivers an amplified picosecond-pulse train with low noise and represents an ideal compact and cost-effective source for various nonlinear Raman spectroscopy and nonlinear imaging techniques, such as coherent anti-Stokes Raman-scattering microscopy. With a considerable optimization of the cavity finesse through selection of impedance-matched optics, we expect that amplifications of more than 100 times are experimentally feasible, bringing the pulse energies into the microjoule range. With proper dispersion compensation the current approach can be extended into the sub-20-fs regime.

This work was supported by a National Institutes of Health grant (GM62536-01), by the Office of Naval Research, and by the National Institute of Standards and Technology. E. O. Potma acknowledges financial support from the European Molecular Biology Organization. R. J. Jones is a National Research Council postdoctoral fellow. J. Ye's e-mail address is ye@jila.colorado.edu, and X. S. Xie's is xie@chemistry.harvard.edu.

## References

1. T. Brabec and F. Krausz, *Rev. Mod. Phys.* **72**, 545 (2000).
2. T. B. Norris, *Opt. Lett.* **17**, 1009 (1992).
3. S. H. Cho, F. X. Kartner, U. Morgner, E. P. Ippen, J. G. Fujimoto, J. E. Cunningham, and W. H. Knox, *Opt. Lett.* **26**, 560 (2001).
4. M. Ramaswamy, M. Ulman, J. Paye, and J. G. Fujimoto, *Opt. Lett.* **18**, 1822 (1993).
5. M. S. Pshenichnikov, W. P. de Boeij, and D. A. Wiersma, *Opt. Lett.* **19**, 572 (1994).
6. G. N. Gibson, R. Klank, F. Gibson, and B. E. Bouma, *Opt. Lett.* **21**, 1055 (1996).
7. T. Heupel, M. Weitz, and T. W. Hänsch, *Opt. Lett.* **22**, 1719 (1997).
8. G. T. Maker and A. I. Ferguson, *Appl. Phys. Lett.* **55**, 1158 (1989).
9. G. McConnell, A. I. Ferguson, and N. Langford, *J. Phys. D* **34**, 2408 (2001).
10. E. R. Crosson, P. Haar, G. A. Marcus, H. A. Schwettman, B. A. Paldus, T. G. Spence, and R. N. Zare, *Rev. Sci. Instrum.* **70**, 4 (1999).
11. T. W. Hänsch, T. Heupel, and M. Weitz, "Method and device for generating phase-coherent light pulses," U.S. patent 6,038,055 (March 14, 2000).
12. R. J. Jones and J. Ye, *Opt. Lett.* **27**, 1848 (2002).
13. T. W. Hänsch and B. Couillaud, *Opt. Commun.* **35**, 441 (1980).